

# ROD SEALS

<b>CUSTOMER</b>		<b>DATE</b>	
<b>MATERIAL</b>		<b>QUANTITY</b>	
<i>Fill circle below profile requested</i>		<b>REQUIRED DATE</b>	

\* Secondary Component Required

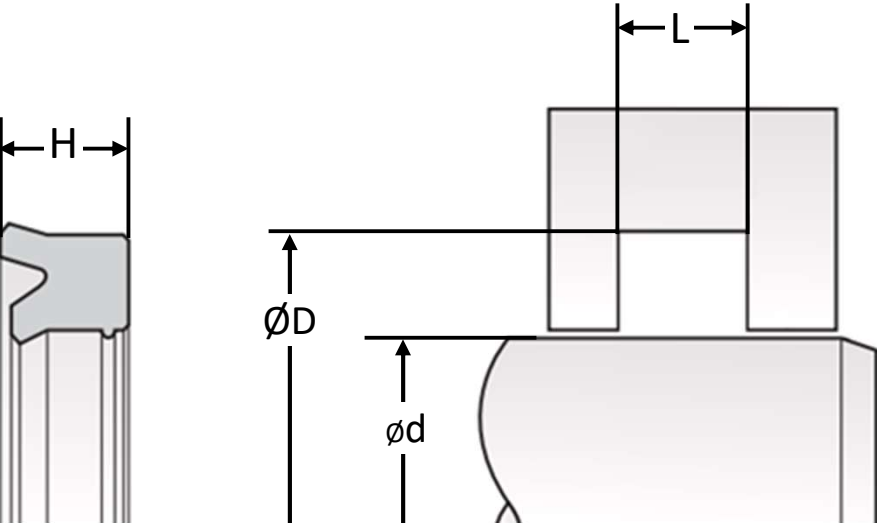

<b>Rod Dia. (<math>\phi d</math>)</b>	
<b>Groove Dia. (<math>\phi D</math>)</b>	
<b>Groove Width (L)</b>	
<b>Seal Height (H)</b>	
<b>*SECONDARY COMPONENTS</b>	
<b>TO BE MACHINED</b>	<b>MATERIAL</b>
LOADER	Y / N
BACK-UP(S)	Y / N

 DS 101 ○	 DS 102* ○	 DS 102R* ○	 DS 103 ○	 DS 104* ○	 DS 104R* ○
 DS 105 ○	 DS 106 ○	 DS 107 ○	 DS 108 ○	 DS 109 ○	 DS 117 ○
 DS 117R* ○	 DS 120* ○	 DS 121 ○	 DS 124 ○	 DS 125 ○	 DS 125R* ○
 DS 129 ○	 DS 129B ○	 DS 131 ○	 DS 138* ○	 DS 139 ○	 DS 141 ○
 DS 142 ○	 DS 199 ○	 DS 205 ○	 DS 216 ○	 DS 238* ○	

NA

ADAPTER MATERIAL	
FEMALE	
MALE	
QUANTITY OF V-RINGS	

 DS 111* ○	 DS 127* ○	NA
------------------	------------------	----

**NOTES:**